

NOTE: BASE SHALL BE AT STATED 1/4" PER FOOT CROSS SLOPE PRIOR TO CONSTRUCTION OF TRAIL.

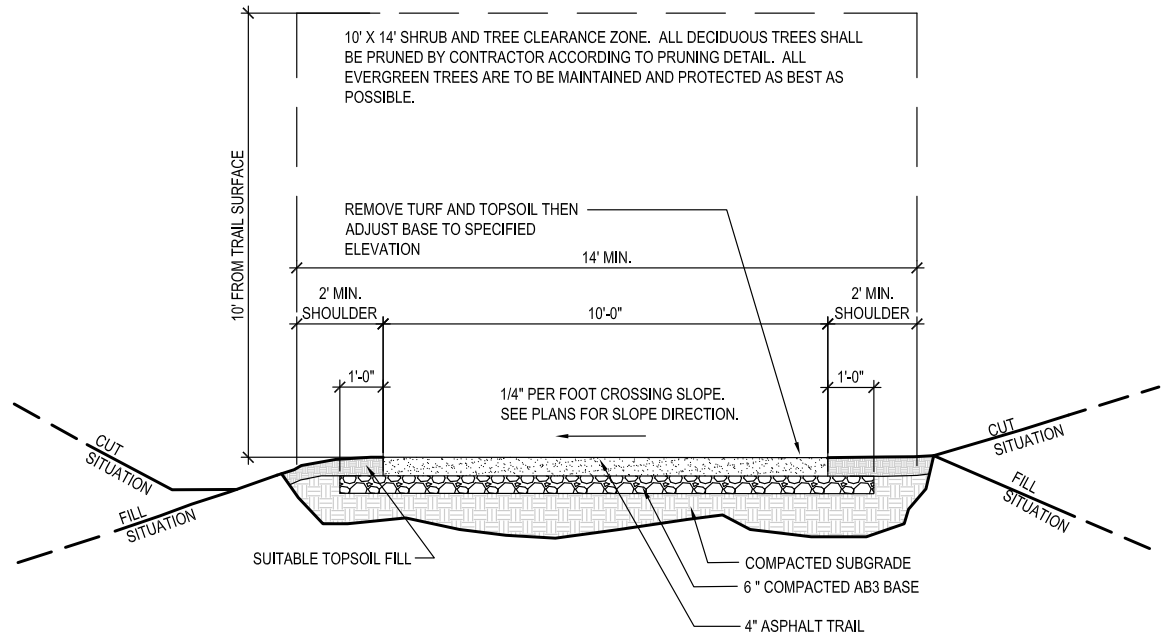

CROSS-SECTION

## Asphalt Trail Construction Detail

NOTE: BASE SHALL BE AT STATED 1/4" PER FOOT CROSS SLOPE PRIOR TO CONSTRUCTION OF TRAIL.

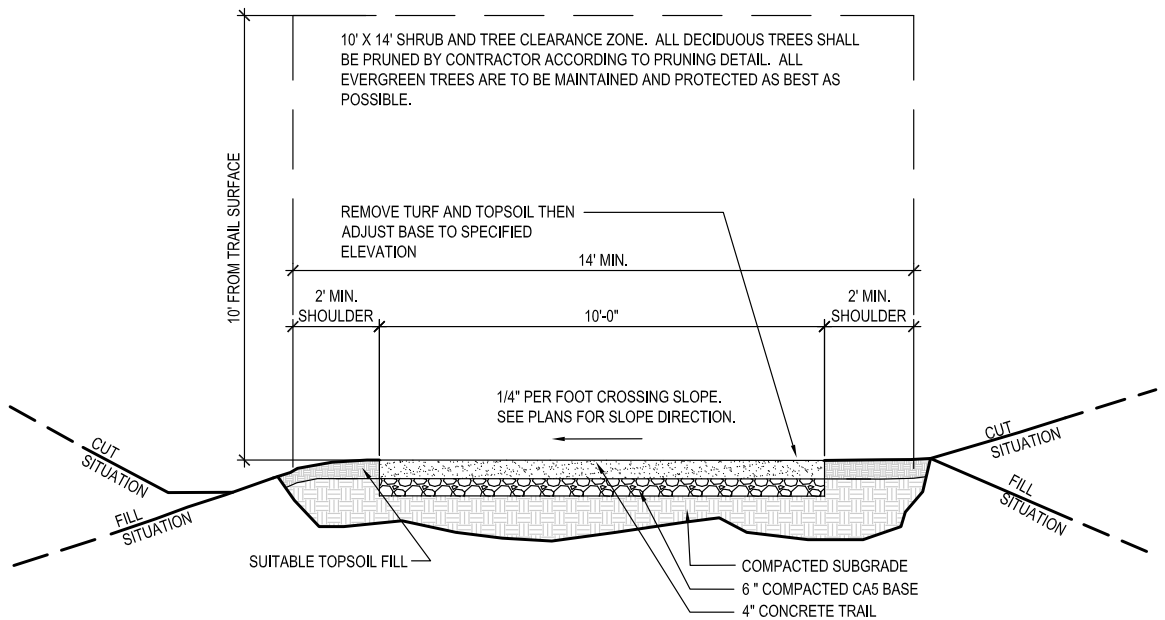

CROSS-SECTION

## Concrete Trail Construction Detail

This page intentionally left blank

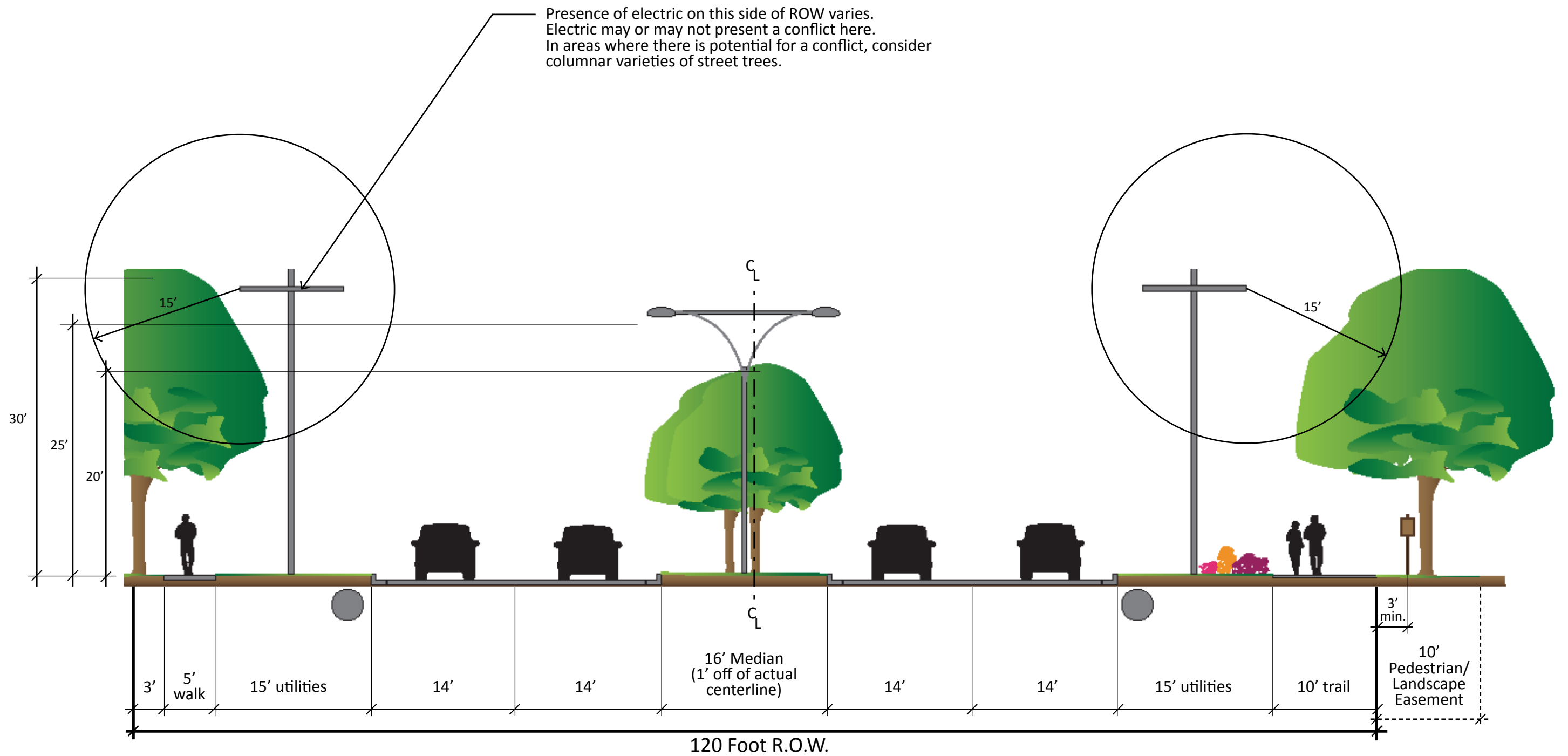

Potential Trail Placement within Street Right-of-Way

Option A

This page intentionally left blank

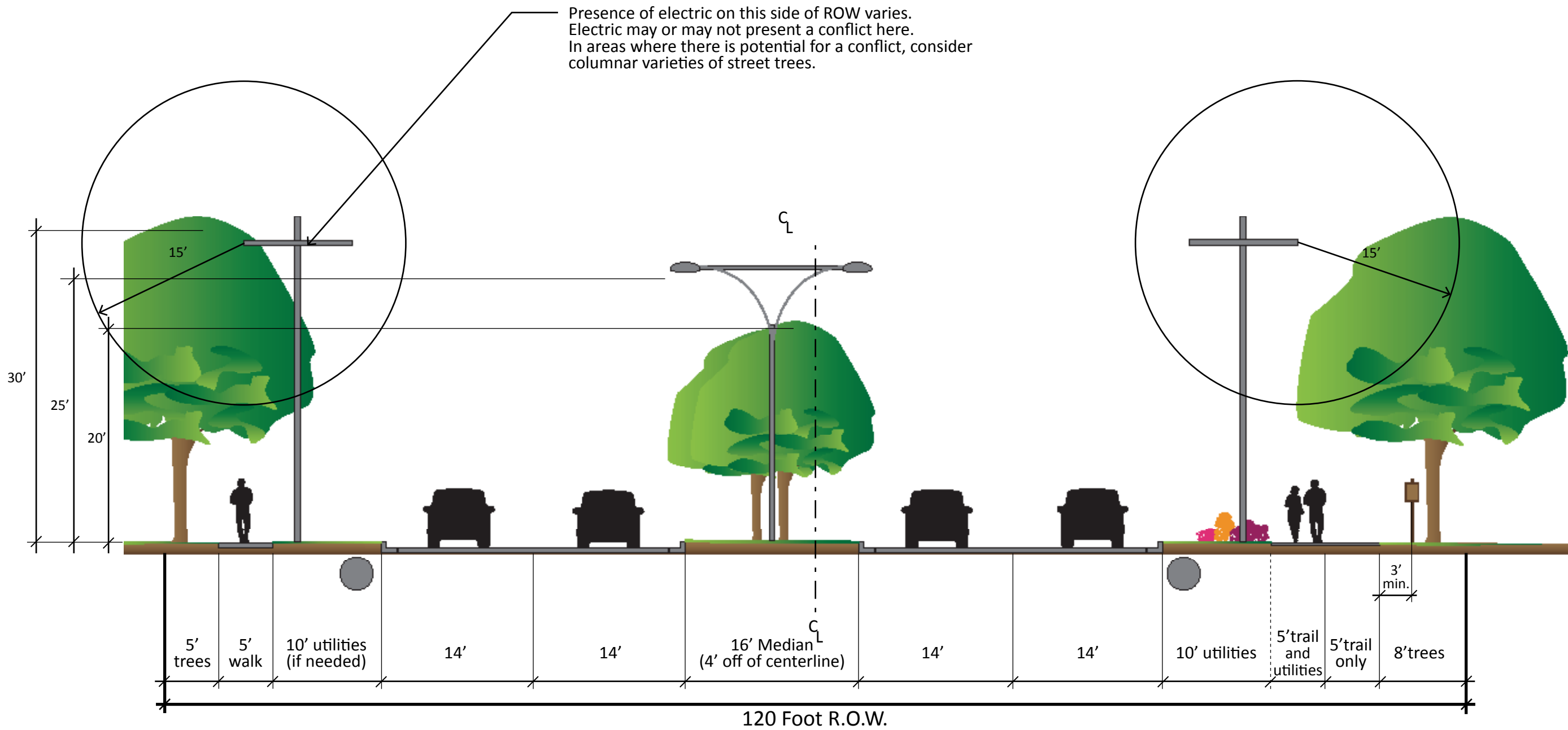

Potential Trail Placement within Street Right-of-Way

Option B

This page intentionally left blank